Appendix A – WDT1776

[REDACTED]

[REDACTED]

Queue Cluster 14 Phase I Report

September 15, 2022

This study has been completed in coordination with the California Independent System Operator Corporation (ISO) per Southern California Edison Company's Wholesale Distribution Access Tariff (WDAT), Attachment I Generator Interconnection Procedures (GIP)

This document may include confidential trade secrets, Critical Energy Infrastructure Information (CEII), and proprietary information of Southern California Edison (SCE) to be used by «IC», in connection with its evaluation of this QC14 Phase I Study. SCE retains all rights to maintain the confidentiality of this information and requires that «IC» preserve its confidentiality.

CONTENTS

A. Introduction	1
B. Report Objective.....	1
C. Description of Generating Facility.....	2
D. Study Assumptions	6
E. Study Results	9
F. Affected Systems	14
G. Deliverability Assessment Results.....	14
H. Metering	15
I. Interconnection Facilities, Network Upgrades, and Distribution Upgrades	15
J. Cost and Duration Estimate.....	15
K. In-Service Date and Commercial Operation Date Assessment.....	18
Attachment 1: Interconnection Facilities, Network Upgrades, and Distribution Upgrades	21
Attachment 2: Escalated Cost and Time to Construct for Interconnection Facilities, Reliability Network Upgrades, Delivery Network Upgrades, and Distribution Upgrades	22
Attachment 3: Allocation of Network Upgrades for Cost Estimates and Maximum Network Upgrade Cost Responsibility	23
Attachment 4: SCE’s Interconnection Handbook.....	24
Attachment 5: Short-Circuit Duty Calculation Study Results	25
Attachment 6: IC Provided Generating Facility Dynamic Data	26
Attachment 7: Subtransmission Assessment Report.....	27

A. INTRODUCTION

██████████, the Interconnection Customer (“IC”), has submitted a completed Interconnection Request (“IR”) to Southern California Edison (“SCE”), the Distribution Provider, for its proposed City of ██████████. The IC’s IR requested Full Capacity Deliverability Status (“FCDS”) for the Generating Facility. In addition, the IC requested an In-Service Date (“ISD”) and Commercial Operating Date (“COD”) ██████████ respectively. However, the ISD and COD for the Generating Facility will depend on the estimated duration required for licensing, engineering, detailed design, procurement, and construction requirements to interconnect the Generating Facility. The estimated duration for these activities would commence after the Generator Interconnection Agreement (“GIA”) for the Generating Facility has been executed and/or filed at the Federal Energy Regulatory Commission (“FERC”) for acceptance and funded.

In accordance with FERC’s approved SCE’s Wholesale Distribution Access Tariff (“WDAT”) Attachment I Generator Interconnection Procedures (“GIP”), the Generating Facility was grouped with Queue Cluster 14 (“QC14”) Phase I projects to determine the impacts of the group as well as impacts of the Generating Facility on SCE’s Distribution System and the ISO Grid. An Area Report and, where applicable, a Subtransmission Assessment Report (“SAR”) have been prepared separately to discuss the combined impacts of all projects on the ISO Grid and to the distribution facilities served out of the ██████████ kV System, respectively. This Appendix A report focuses only on the impacts or impact contributions of the Generating Facility to SCE’s Electric System and is not intended to supersede any contractual terms or conditions specified in a forthcoming GIA.

B. REPORT OBJECTIVE

SCE performed a QC14 Phase I Study that included the Generating Facility, and this report addresses the results of the analysis.

The report provides the following:

1. Transmission and Distribution system impacts attributed to the proposed Generating Facility.
2. System reinforcements or mitigation necessary to address the adverse impacts attributed to the Generating Facility under various system conditions.
3. A list of required facilities and a good faith estimate of the IC’s cost responsibility for its proposed Generating Facility and SCE’s project execution schedule¹. Such information is provided in Attachment 1 and Attachment 2 as separate documents in the Appendix A report package for the Generating Facility. Specifically, the facilities that will be installed by SCE and the IC are detailed in Attachment 1.
4. Identification of potential short circuit duty impacts to Affected Systems served from the Transmission, Subtransmission or Distribution System.

¹It should be noted that construction is only part of the estimated duration of months specified in the study, which includes final engineering, licensing, and other activities required to bring such facilities into service. These durations are from the execution of the GIA, receipt of: all required information, funding, and written authorization to proceed with design and engineering, procurement, and construction from the IC as will be specified in the GIA to commence the work.

C. DESCRIPTION OF GENERATING FACILITY

Generating Facility: all equipment and facilities comprising the IC’s City of [REDACTED] located in the City of [REDACTED], California, as disclosed by the IC in its IR, as may have been amended during the Interconnection Study process, as summarized below:

Table C.1: [REDACTED]

[REDACTED]	
[REDACTED]	
[REDACTED]	[REDACTED]
[REDACTED]	
[REDACTED]	
Generating Facility Output	Solar PV
Total rated (gross) capacity at inverter terminals:	[REDACTED] [REDACTED]
Total net capability at high-side of main step-up transformer(s):	[REDACTED] [REDACTED]
Total net capacity at high-side of main step-up transformer(s):	[REDACTED]
Total net capacity at Point of Interconnection (“POI”):	[REDACTED]

Note: Detailed loss analysis used in defining net capability at high side of main transformer bank and net capacity at the POI

Generation Export Limit for the Generating Facility

The IC has requested a total net capacity of [REDACTED] MW as measured at the high-side of the main step-transformer(s) and [REDACTED] net MW at the POI. The Parties acknowledge that should the Generating Facility exceeds these values or is capable of exceeding these values the IC agrees to: install, own, operate and maintain a control limiting device or, alternatively, by means of configuring the Generating Facility’s control system. This is to ensure the Generating Facility does not exceed the total net capacity at the high-side of the main step-up transformer(s) and at the POI.

The scope of facilities, required to interconnect the proposed Generating Facility and provide the requested [REDACTED] net MW output at the POI, are detailed in Attachment 1 to this Appendix A report. The proposed plan for interconnecting the Generating Facility is illustrated in Figure C.1. and Figure C.2 illustrates the proposed location of the Generating Facility. Additional information is provided in Table C.2

Figure C.1: [REDACTED]

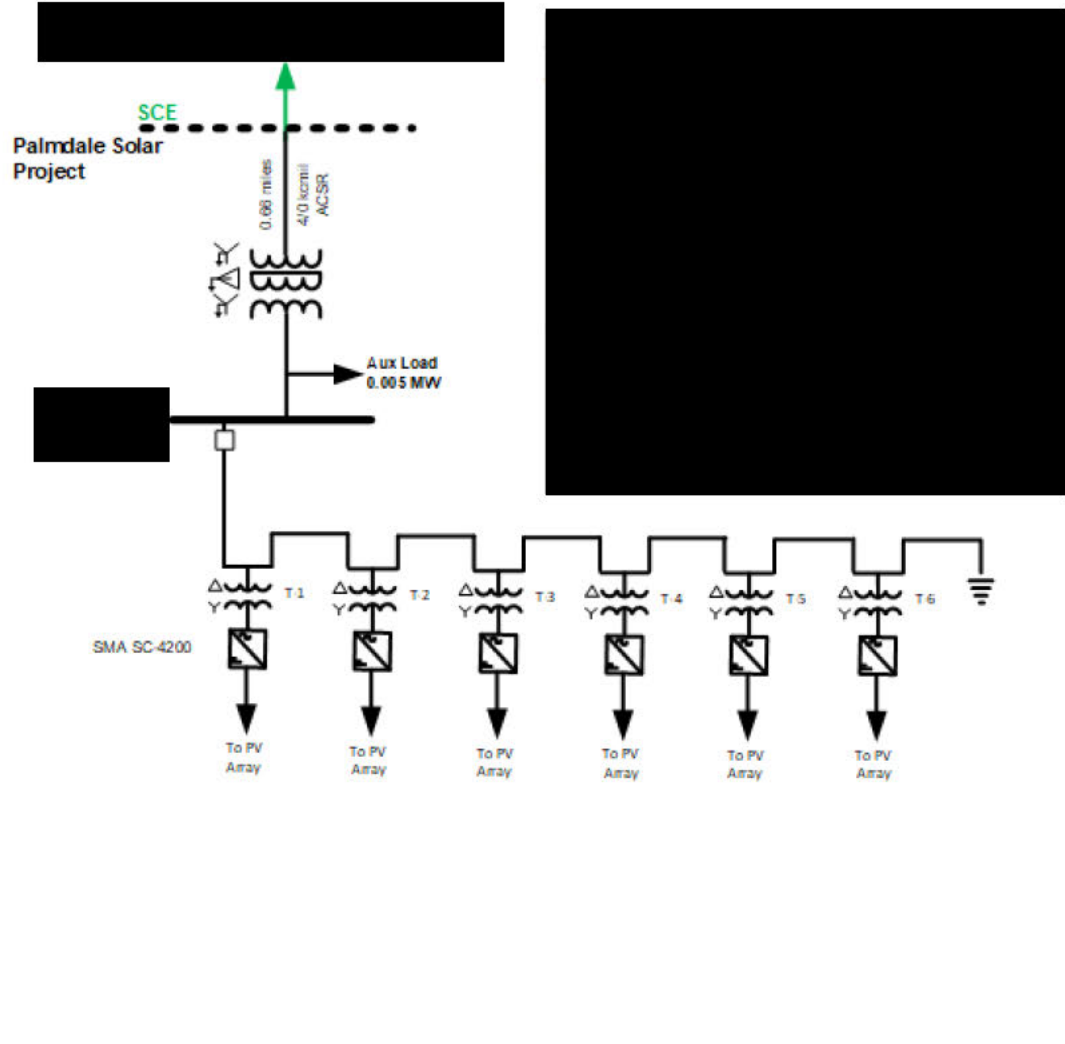

Figure C.2: [REDACTED]

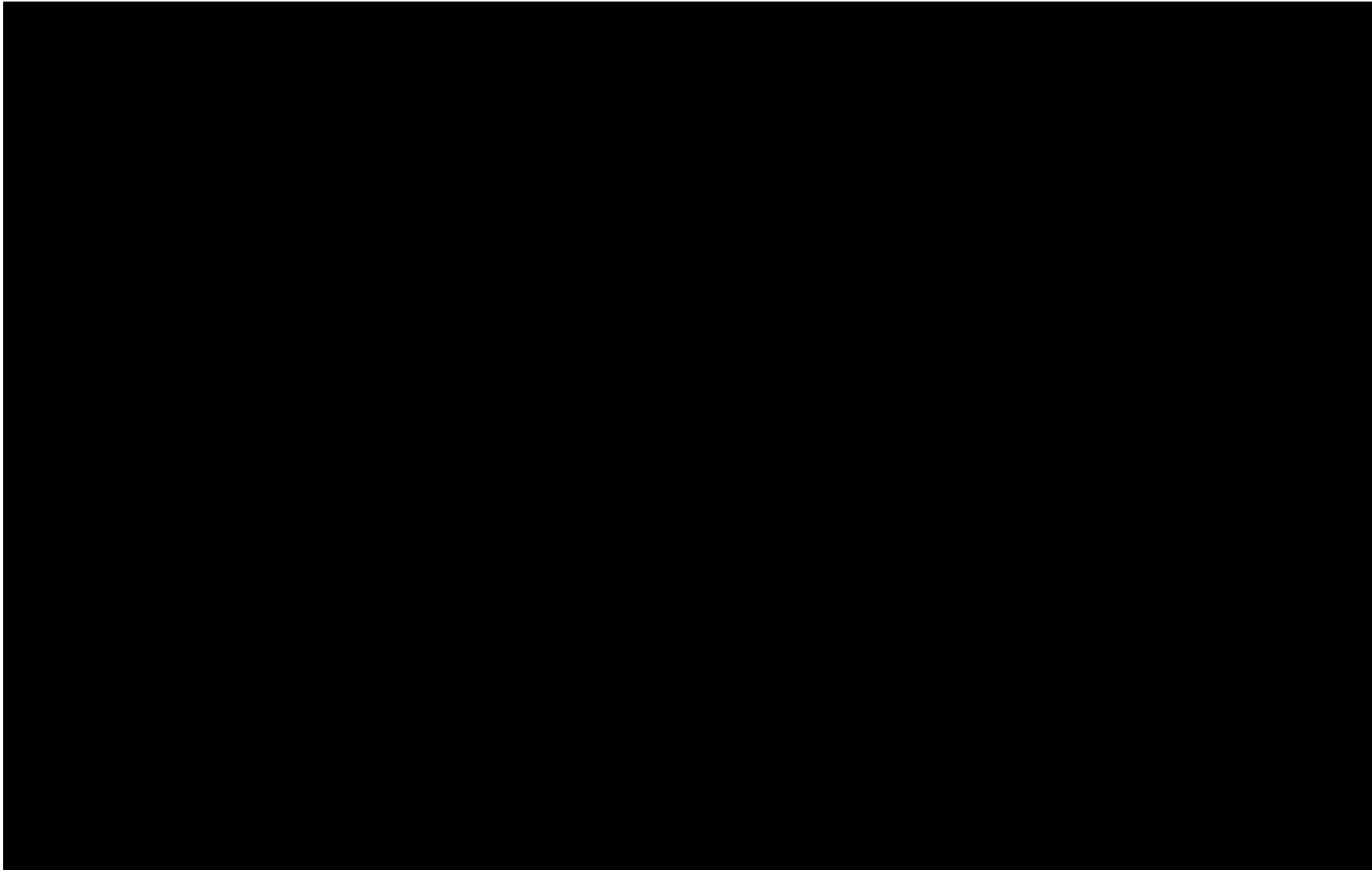

Table C.2: [REDACTED]

Generating Facility Location	[REDACTED]
SCE's Planning Area	[REDACTED]
Interconnection Voltage	[REDACTED]
POI	[REDACTED]
High Fire Risk Area	[REDACTED]
Requested Maximum Generating Facility Delivery at Point of Interconnection ²	[REDACTED]
Number and Types of Generators	[REDACTED]
[REDACTED]	[REDACTED]
Main Step-Up Transformer(s) Main Transformers T1	[REDACTED]
Collector Equivalent	[REDACTED]
Pad-Mount Transformer(s) Downstream of Main Transformer Bank T1	[REDACTED]
Generator Data Downstream of Main Transformer Bank T1	[REDACTED]
Generator Auxiliary Load and/or Station Light and Power	[REDACTED]
Voltage Regulation Devices Downstream of Main Transformer Bank T1	[REDACTED]
Dynamic Models Used	[REDACTED]

The Generating Facility was modeled as described in Table C.1 and C.2 above.

² The MW output at the POI varies under different operating conditions. The IC is reminded that this value is tied to the generation tie-line (gen-tie) losses. The estimated Maximum Net Output value at POI and gen-tie losses illustrated above are contingent upon the accuracy of the technical data provided by the IC and are subject to change should the IC change its gen-tie parameters during the final engineering and design phase of the Generating Facility. [REDACTED]

D. STUDY ASSUMPTIONS

For detailed assumptions regarding the evaluation on the SCE Transmission and Subtransmission System, please refer to the QC14 Phase I Area Report and SAR, respectively. Below are the assumptions specific to the proposed Generating Facility:

I. Environmental Activities, Permits, and Licensing.

Table D.3 Environmental Activities & Licensing evaluation per SCE Facilities or Upgrades

SCE Facility or Upgrade Classification	Assumed Licensing (y/n)	Environmental Activities Assumed Roles and Responsibilities		Declaration Required (y/n)
		IC/SCE-Shared	SCE Only	
IF	N	X		Y
DU				
Other				
RNU	[REDACTED]			[REDACTED]
LDNU				
ADNU			X	
Shared DU			X	

For further details on the environmental evaluation and permitting/licensing requirements for generator interconnection projects, refer to Appendix K of the Area report.

If no "X", "Y", or "N" is entered in a specific row of Table D.3, then assume no environmental scope of work or costs would apply to such SCE facilities disclosed in Attachment 1.

Assumed Licensing:

- If yes is indicated in Table D.3, SCE assumes construction of SCE's Interconnection Facilities ("IF") and/or Distribution Upgrades ("DU") needed to interconnect the Generating Facility will require a California Public Utilities Commission ("CPUC") license.
- If no is indicated in Table D.3, SCE assumes construction of SCE's IF and/or DU needed to interconnect the Generating Facility will not require a CPUC license.
- Such assumptions will be reviewed and verified after execution of a Generator Interconnection Agreement ("GIA") when detailed engineering and environmental review occur.

Environmental Activities Assumed Roles and Responsibilities:

- If "IC/SCE-Shared" is marked in Table D.3:

SCE Scope of Work

1. SCE will act as the lead for regulatory agency communication for permits issued to SCE covering such SCE facilities.
2. If licensing is assumed, SCE will file for an “expedited” Certificate of Public Convenience and Necessity or “expedited” Permit to Construct by attaching the IC’s certified final California Environmental Quality Act (“CEQA”) document with SCE’s scope of work sufficiently incorporated in lieu of a Proponent’s Environmental Assessment (“PEA”). If a CEQA document is not required for the Generating Facility or if the Generating Facility’s CEQA document does not sufficiently incorporate SCE’s scope of work, SCE may be required to prepare a PEA for SCE’s scope of work. In such cases, SCE’s assumed environmental work and licensing level of effort will increase, resulting in the need to update cost and duration estimates, and potentially amend the GIA.
3. SCE environmental activities may include, but are not limited to, the following:
 - a) Perform all environmental studies and construction monitoring of SCE internal substation construction activities and provide study results to the IC for inclusion in its environmental documents, if applicable.
 - b) Collaborate with the IC during the environmental study phase on the IC’s proposed study methodologies and findings, as studies are being planned and performed for SCE’s scope of work.
 - c) Review IC’s CEQA and/or National Environmental Policy Act (“NEPA”) documents, technical studies, surveys, and other environmental documentation to ensure SCE’s scope of work is adequately described in such documents (IC will include SCE’s scope of work in its environmental documents. If the Generating Facility’s CEQA and/or NEPA documents do not sufficiently incorporate SCE’s scope of work, SCE’s assumed environmental work and permitting level of effort may increase, resulting in the need to update cost and duration estimates, and potentially amend the GIA).
 - d) Review SCE’s internal existing technical reports/documents when available.
 - e) Prepare SCE’s project description, including scope changes during permitting/pre-construction or construction.
 - f) Communicate scope changes to the IC’s environmental team and discuss/approve subsequent actions including new surveys as necessary.
 - g) Complete General Order 131-D Consistency Determination and Environmental Evaluation.
 - h) Regulatory agency communication, consultation, reporting, and acquisition of SCE permits addressing SCE’s facilities and scope of work.
 - i) Prepare environmental requirements for construction clearance.
 - j) Develop communication plan.
 - k) Perform pre-construction coordination field visit.
 - l) Provide Environmental Awareness/Worker Environmental Awareness Program (“WEAP”) training.
 - m) Perform construction monitoring oversight.
 - n) Complete construction and post-construction site assessments.

IC Scope of Work

1. IC will perform all environmental studies and prepare draft environmental permit applications related to the installation of such SCE facilities, except for the SCE

- internal substation activities as described above. The IC’s responsibilities include as applicable, but are not limited to: notifications to the Native American Heritage Commission (“NAHC”) and follow-up notifications to the tribes and individuals in the NAHC contact list; performing cultural and paleontological resources records searches, cultural resources inventories (survey and recording), testing and evaluation and/or data recovery of archaeological sites, and appropriate documents in the form of inventory reports, research design, and/or data recovery reports; cultural and paleontological monitoring when/if required, and arranging curation agreements for artifacts and fossil specimens collected; performing a California Natural Diversity Database search, habitat assessment, and protocol or focused surveys for species with the potential of occurring in identified suitable habitat; conducting jurisdictional delineations for wetlands and other regulated waters; preparing draft environmental permit applications, pre-construction biological resource surveys for such SCE facilities, biological resource monitoring during construction of such SCE facilities; mitigation costs including, but not limited to, offsite/compensatory mitigation and onsite restoration, and developing mitigation plans or other environmental reports or submittals to support installation of such SCE facilities.
2. Prior to commencing work and during execution of work, the IC should collaborate and obtain SCE concurrence on all work outlined above. Should the IC-performed environmental studies, surveys, or construction monitoring not meet the Federal or State industry standards in accordance with Applicable Laws and Regulations, and as determined by SCE, the IC shall be obligated to remedy deficiencies under SCE’s direction.
- ii. If “SCE Only” is marked in Table D.3:
1. SCE will perform all required environmental studies, prepare environmental permit applications, obtain required environmental permits, and perform required monitoring of all SCE construction activities, and undertake habitat mitigation as required, including, but not limited to, offsite/compensatory mitigation and onsite restoration, related to the installation of such SCE facilities.
 2. Under certain circumstances, such SCE facilities may need to be described and analyzed as part of the IC’s CEQA and/or NEPA documents for the Generating Facility. Further coordination to discuss these circumstances may occur during GIA negotiations and/or after GIA execution. Any changes to the environmental and licensing assumptions may result in the need to update cost and duration estimates, and potentially amend the GIA.

Declaration Required:

As a requirement for Interconnection Customers’ shared responsibility to perform the Environmental Activities for SCE-owned IF and DU as disclosed above, and to ensure proper accounting of costs used in the calculation of the ITCC and Operations & Maintenance (“O&M”) charges, referred to as an Interconnection Facilities Charge and/or a Distribution Upgrades Charge, if applicable, in the forthcoming GIA for the Generating Facility, the IC is required to complete and submit an Environmental Services Costs Declaration for SCE-owned IF and/or DU required to interconnect the Generating Facility. An authorized representative of the IC will sign the declaration attesting to the actual costs spent on environmental services work that would otherwise have been performed by SCE for SCE-owned IF and DU (if applicable) required to interconnect the Generating Facility.

The declaration shall be provided to SCE by a specified date in the Generating Facility's forthcoming GIA Appendix B - Milestone table. Should the IC fail to provide the declaration by the specified deadline, SCE will hold the IC in default of the GIA pursuant to the terms therein. The costs stated by the IC in the declaration, once approved, will be used by SCE to adjust the ITCC and the applicable monthly O&M charges for the Generation Facility and will be reflected via an amendment to the GIA upon true-up.

The information stated in the declaration is subject to review and/or audit by SCE pursuant to the terms and conditions in the forthcoming GIA. Should an audit be deemed necessary by SCE, the IC will need to provide supporting documentation (copies of invoices/receipts) to substantiate the costs stated in the declaration within ten (10) business days from receipt of notice.

- II. Other Items to Consider:
- NA.

E. STUDY RESULTS

1. ISO Grid

a. Generation Export Analysis

i. Steady State Power Flow Reliability Analysis

The results of the ISO Grid reliability analysis indicate that the Generating Facility contributes to overloads under normal, and/or single contingency, and/or multiple contingency conditions. A combination of congestion management, Area Deliverability Network Upgrade ("ADNU"), Local Delivery Network Upgrades ("LDNU"), and CRAS/RAS are required to mitigate the power flow impacts of the Generating.

Although the generating facility did contribute to various overloads, the approved upgrades mainly focus on ADNUs and RNU that only require generating tripping infrastructure for TOT projects. Thus for RNU no upgrades to the ISO Grid were assigned to the Generating Facility, as a WDAT project.

For information on any LDNU/ADNU assigned to the Generation Facility, if applicable, please refer to section G in this report.

ii. Transient Analysis

In the "Supercluster Interconnection Procedures" paper³, the ISO, in coordination with the PTOs, established reasonable study scenarios and dispatch assumptions for the steady state (thermal and voltage) analysis. Total generation inside the study area will be limited to produce meaningful study results. No system stability analysis was

³ <http://www.caiso.com/Documents/IssuePaper-DraftFinalProposal-SuperclusterInterconnectionProcedures.pdf>

performed in Phase I, however a system stability analysis will be conducted as part of the Phase II Study.

iii. Deliverability Assessment

Section G – Deliverability Assessment Results of this report provides information on any Delivery Network Upgrades (Local or Area) assigned to the Generating Facility, if any.

iv. Short Circuit Duty Analysis

1. SCE-owned Facilities

The QC14 Phase I SCD evaluation to the ISO Grid did not identify any additional overstressed circuit breakers with the inclusion of the projects in QC14 Phase I.

2. SCE's Ground Grid Duty Concerns

The SCD studies flagged certain existing substations for further review where the Phase I projects increased the substation ground grid duty by at least 0.25 kA. Additional review will be performed as part of Phase II to determine if any of these locations will require a detailed ground grid analysis. The ground grid study will be performed as part of project execution once GIAs are in place and projects proceed forward towards interconnection. Refer to the Area Report for further information.

3. SCD Considerations

The ISD and/or COD of the Generating Facility may be impacted by SCD upgrade(s)/mitigation(s), that were triggered in prior cluster studies and are required only when enough generation projects (with executed GIAs in good standing) achieve ISD. The identification of the need for these upgrades assumes that all queued generation projects materialize and are interconnected, but the true need occurs only when enough queued generation achieves ISD. These SCD mitigations will be continuously evaluated as part of subsequent planning studies and the Annual Reassessment with queued generation projects to properly define the actual trigger of SCD mitigation based on the actual execution of GIA and development of generation facilities toward commercial operation. For previously triggered SCD mitigation(s), if any, that could impact the timelines for Generating Facility Please refer to Area Report which are titled the following:

- a. Upgrades identified through the GIDAP which are included in an executed generator interconnection agreement, but are not yet in-service
- b. Upgrades identified through the ISO Transmission Planning Process

b. Charging Analysis

Not applicable

2. Non-ISO controlled Subtransmission System [REDACTED]

a. Generation Export Analysis

i. Steady State Power Flow Analysis

1. Thermal Overloads

The subtransmission assessment indicates that the Generating Facility contributes to overloads on subtransmission facilities under normal, single, and multiple contingency conditions. The details of the analysis with overload level information, and associated recommended mitigation, is provided in the corresponding Subtransmission Assessment Report. Provided below is a summary of this information.

I. Normal Conditions

- No thermal overloads have been identified.

II. Single Contingency

- No thermal overloads have been identified.

2. Power Flow Non-Convergence

There were no non-convergence issues identified with the inclusion of the Generating Facility operating at the required power factor range; refer to Area Report and/or Subtransmission Assessment Report for additional details.

3. Voltage Performance

There were no voltage performance issues identified with the inclusion of the Generating Facility; refer to Area Report and/or Subtransmission Assessment Report for additional details.

4. Required Mitigations

The Generation Facility does not trigger or contribute to any overloads under the generation export scenario, therefore there is no mitigation required related to the power flow analysis.

5. Line Loss Analysis for Generating Facility

Based on the technical data provided for the individual generator unit(s), the collector system equivalent, pad-mount and main transformer banks, the internal Generating Facility losses are shown in Table E.1. In addition, losses incurred on the generation tie- line are shown in Table E.2 below. The Generating Facility losses identified represent those assuming the Generating Facility is limiting its output at the high side of the main transformer bank to achieve the desired MW delivery at the POI.

Table E.1

Resource	Gross Output to Achieve Desired Output at POI (MW)*	Internal Generating Facility Losses (MW)			Aux Load (MW)	Net Output (MW)
		Pad-Mount	Collector	Main Transformer		
WDT1776 Solar PV (Discharge)	██████	██████	██████	██████	██████	██████

*This represents the MW value needed at the inverter terminal to achieve the desired Net Output MW in order to meet the requested POI MW.

Table E.2

Resource	Net Output* (MW)	Losses on Interconnection Facilities (MW)		POI (MW)
		Generating Facility Gen-Tie		
WDT1776 Solar PV (Discharge)	██████	██████		██████

*MW (net) represents the MW value as measured on the high side of the main transformer bank to achieve the desired MW delivery at the POI.

6. Power Factor Evaluation

FERC Order 827 provides the reactive power requirements for newly interconnecting non-synchronous generators which requires these resources to design the facility to be capable of providing reactive power to meet power factor 0.95 as measured on the high-side of the IC’s substation or other equivalent location. This capability should be dynamic.

Base case power flow was evaluated to determine reactive power losses internal to the Generating Facility to ascertain if the reactive capability of the Generating Facility is adequate to supply these losses and meet the power factor requirements. A summary of the power factor evaluation is provided in the table below.

Evaluation Assumptions		
	Average Temperature	Hist. Max Temp
Ambient Temperature for Generator Capability (°C)	██████	██████
Generating Facility MW Output at Terminal (MW)	██████	██████
Effective Power Factor at Generator Terminal	██████	██████
Generating Facility MW at High Side of the Transformer (MW)	██████	██████
Reactive Power Requirements		
Pad-mount transformer losses (MVAR)	██████	██████
Collector equivalent losses (MVAR)	██████	██████
Main transformer losses (MVAR)	██████	██████
PF Requirements at High Side of Transformer (MVAR)	██████	██████
Total VAR Requirements (MVAR)	██████	██████
Reactive Power Supply		
PV Inverters at Pgen (MVAR)	██████	██████
Shunt Capacitors (MVAR)	█	█
Collector Line Charging (MVAR)	██████	██████
Other Dynamic VAR Devices (MVAR)	█	█
Total VAR Supply (MVAR)	██████	██████
Total Dynamic VAR Supply (MVAR)	██████	██████
Total Reactive Power (Shortage) VAR Supply / Surplus		
Total VAR Requirements less Total VAR Supply	██████	██████
Dynamic Reactive Power (Shortage) / Surplus		
PF Requirements at High Side of Transformer less Total Dynamic VAR Supply	██████	██████

Based on the technical details provided, the Generating Facility, as proposed, does have the capability to meet 0.95 power factor requirement as measured at the high-side of the IC's substation or other equivalent location.

ii. Transient Analysis

As noted previously in Section E.1.a.ii, no system stability analysis was performed in the Phase I study, however a system stability analysis will be conducted as part of the Phase II Study

iii. Short Circuit Duty Analysis

1. SCE-owned Facilities

The QC14 Phase I SCD evaluation at the subtransmission level identified additional overstressed circuit breakers triggered with the inclusion of the projects in QC14 Phase I.

The Generating Facility was found to contribute to over duty issues and as a result was assigned the following SCD mitigation upgrades:

■ [REDACTED]

Please refer to the Subtransmission Assessment Report for additional details on the study, and to the Attachment 1 and Attachment 2 documents for scope and costs information related to these upgrades.

2. SCE's Ground Grid Duty Concerns

The SCD studies flagged certain existing substations for further review where the Phase I projects increased the substation ground grid duty by at least 0.25 kA. Additional review will be performed as part of Phase II to determine if any of these locations will require a detailed ground grid analysis. The ground grid study will be performed as part of project execution once GIAs are in place and projects proceed forward towards interconnection. Refer to the Area Report for further information.

3. Short Circuit Duty Considerations

The ISD and/or COD of the Generating Facility may be impacted by SCD upgrade(s)/mitigation(s), that were triggered in prior cluster studies and are required only when enough generation projects (with executed GIAs in good standing) achieve ISD. The identification of the need for these upgrades assumes that all queued generation projects materialize and are interconnected, but the true need occurs only when enough queued generation achieves ISD. These SCD mitigations will be continuously evaluated as part of subsequent planning studies with queued generation projects to properly define the actual trigger of SCD mitigation based on the actual execution of GIA and development of generation facilities toward commercial operation.

In addition to the above mentioned SCD considerations, the Generating Facility was found to be dependent upon the installation of additional SCD upgrade(s) listed below. Although the IC is not financially responsible for the SCD upgrade(s) listed below, the Generating Facility will need to wait until the project is complete to be placed in-service.

Current SCE Sponsored SCD Upgrades

SCD Upgrade	Estimated COD
[REDACTED]	[REDACTED]

b. As-Available Charging Analysis

- Not Applicable

F. AFFECTED SYSTEMS

Per GIP Section 3.7, SCE will notify the Affected System⁴ Operators that are potentially affected by the active projects in QC14 Phase I. Given the radial nature of SCE’s non-ISO controlled subtransmission system, the impacts to Affected Systems connected to such system is limited to incremental SCD at the interface point with the Affected System. As part of this study, SCE evaluates the incremental SCD at the interface point with the potential Affected System. Locations where SCD is increased by at least 0.1 kA will be documented in the study results providing the incremental SCD contribution associated with the active projects in QC14 Phase I.

The specific SCD contribution from the Generating Facility to the interface point between SCE and the potentially Affected System is provided in Table F.1 below. Impacts on the Affected Systems with the addition of all QC14 Phase I projects, are provided in the Area Report (Section H.2), and in Attachment 7.

Table F.1: Short-Circuit Duty Evaluation of Neighboring Utilities Impacted by the Generating Facility

Substation	Voltage	Entity	Generating Facility Impact	
			3-Phase (kA)	Single Line-to-Ground (kA)
[REDACTED]	[REDACTED]	[REDACTED]	[REDACTED]	[REDACTED]
[REDACTED]	[REDACTED]	[REDACTED]	[REDACTED]	[REDACTED]
[REDACTED]	[REDACTED]	[REDACTED]	[REDACTED]	[REDACTED]
[REDACTED]	[REDACTED]	[REDACTED]	[REDACTED]	[REDACTED]
[REDACTED]	[REDACTED]	[REDACTED]	[REDACTED]	[REDACTED]
[REDACTED]	[REDACTED]	[REDACTED]	[REDACTED]	[REDACTED]
[REDACTED]	[REDACTED]	[REDACTED]	[REDACTED]	[REDACTED]
[REDACTED]	[REDACTED]	[REDACTED]	[REDACTED]	[REDACTED]

G. DELIVERABILITY ASSESSMENT RESULTS

Please refer to Section E of the Northern Area Report included in the QC14 Phase I report package for the details on the QC14 Phase I Deliverability Assessment.

⁴ Affected System shall mean an electric system other than the SCE's Distribution System that may be affected by the proposed interconnection. For purposes of this compliance requirement, Affected Systems will consist of neighboring municipalities.

For scope and cost information of any Network Upgrades assigned to the Generating Facility, please refer to Attachment 1 and Attachment 2 of this Appendix A report.

H. METERING

The IC did not provide SCE a detailed one-line diagram prior to the Phase I Studies that shows the Generating Facility's proposed metering configuration ("metering one-line"). As a result, the Phase I Study metering scope and costs was based on preliminary engineering and design and subject to change. Therefore, the IC per SCE's Interconnection Handbook Section 6.3 and GIP Section 9.3, shall provide SCE with a detailed metering one-line ten (10) Business Days following the Phase I Results Meeting. The approved metering one-line will enable SCE to determine the number of meter sets required to meter the Generating Facility in compliance with its metering tariff(s) requirements.

If the IC fails to provide an approved metering one-line in accordance with SCE's Interconnection Handbook Section 6.3 and GIP Section 9.3, the Phase II Study metering scope and cost will be based on a proxy methodology that would presumably enable SCE to comply with its metering tariff(s) requirements. Since the IC is required to comply with SCE's Interconnection Handbook and GIP, the IC's Generating Facility's metering configuration will be evaluated post Phase II or post GIA. If post GIA, finalizing the Generating Facility's metering one-line diagram and determining the number of meter sets required to comply with SCE's metering tariff(s) requirements will be performed in parallel with the engineering and design phase of the Generating Facility. This post GIA analysis may result in additional metering scope and cost and may impact the IC's requested ISD and COD. Any change to the Generating Facility's interconnection configuration or technology after the Phase II study, including the metering configuration, will require the IC to submit an MMA request in accordance with the GIP.

I. INTERCONNECTION FACILITIES, NETWORK UPGRADES, AND DISTRIBUTION UPGRADES

Please see Attachment 1 for SCE's Interconnection Facilities ("IF"), RNU', Delivery Network Upgrades⁵ (DNU), and Distribution Upgrades ("DU") allocated to the Generating Facility for physical interconnection, to provide for the requested net MW export at the POI taking into consideration the IC's requested Deliverability, and in support of the IC's request for ACDS. Please note that SCE considered current system configuration, approved SCE sponsored projects, and all queued generation in determining scope for IF and/or plan of service but will not "reserve" the identified scope of upgrades for the proposed POI unless a GIA is executed per the specified timelines shown in Tale H.1.

J. COST AND DURATION ESTIMATE

I. Cost Estimate

The Generating Facility's estimated interconnection costs, adjusted for inflation and provided in 'constant' 2022 dollars escalated to the Generating Facility's feasible COD (as identified below in Table H.1), are provided in Attachment 2 and the Generating Facility's allocated cost for shared network upgrades are provided in Attachment 3 to this Appendix A report. The interconnection costs will be documented in the forthcoming GIA for the Generating Facility. However, should

⁵ At the IC's discretion, the IC or parties other than SCE pursuant to Section 10.2 under GIP may construct an Option (B) Generating Facility Area Delivery Network Upgrades (ADNUs) not allocated TP Deliverability. If SCE does not construct the ADNUs, the IC is not required to make the third Interconnection Financial Security posting to SCE pursuant to Section 4.8.4.2.1 under GIP.

there be a delay in executing the GIA beyond 2024, a new cost estimate adjusted for inflation will be required and reflected into the GIA.

II. Preliminary Durations

The estimated duration(s) shown in Table G.1 represents the estimated time needed for SCE to design, engineer, procure, and construct the applicable facilities with the start date of the estimated duration based on the effective date of the GIA; and timely receipt of all required information, written authorization to proceed (“ATP”), project payments, financial security postings, and timely completion of project milestones. The estimated durations for the facilities identified for the Generating Facility are as follows:

Table G.1 Estimated Execution Duration

Facilities	Description	Duration (Months) ⁶	Notes
Interconnection Facilities (IF)	Facilities described in Section 1.b of Attachment 1	■	■
Reliability Network Upgrades (RNU)	No required RNU were identified in the Phase I Interconnection Study	■	■
Stand Alone Network Upgrades (SANU)	NA	■	■
Area Delivery Network Upgrades (ADNU)	ADNU described in Section 2 of Attachment 1	■	■
Local Delivery Network Upgrades (LDNU)	No required LDNU were identified in the Phase I Interconnection Study.	■	■
Distribution Upgrades (DU)	DUs described in Section 3 of Attachment 1	■	■

Notes:

1. Duration Estimates and Identified Upgrades

Durations identified in this section may vary. During the cluster study process, SCE includes all queued and active generation projects without regard to corresponding

⁶ **Short Circuit Duty Mitigation Durations:** It is important to note that short-circuit duty upgrades identified as part of the QC14 Phase I interconnection studies were derived with the inclusion of all active higher-queued generation projects without regard to corresponding desired in-service dates or actual project status. Changes to the higher-queued generation projects as well as changes to generation projects in QC14, such as withdrawals, downsizing, suspensions, or deferrals to proposed in-service dates, may allow for the identified earliest in-service to be accelerated to align with the construction timing for the plan of service and Interconnection Facilities needed to interconnect the project. Ultimately, SCD upgrades will be scheduled based on actual development of generation resources identified to meaningfully increase SCD on the identified overstressed circuit breakers as determined based on execution of Generation Interconnection Agreements or other agreements that commit a project towards development.

desired in-service dates or actual status to identify system upgrades, including SCD related upgrades, and a duration for SCE to build them. Such duration affects the ISD for this specific Generating Facility. As status for queued projects change (withdrawals, downsizing, suspensions, or deferred in-service dates), SCE may be able to accelerate in-service dates for projects affected by status changes. Furthermore, SCE will only begin design/construction of an identified system upgrade when enough projects 1) execute and fund a GIA and/or a Letter Agreement with SCE and 2) those projects trigger the need for an upgrade.

2. Coordination of Environmental Work

This study assumes that the IC will perform environmental work related to the installation of SCE's IF, and DU as specified in this report. The IC is advised that any durations provided above assume that the IC will perform this environmental work in parallel with SCE's preliminary design and engineering. The IC is expected to engage SCE to obtain concurrence prior to commencement of any environmental work and during execution of that work. Since SCE will be using the IC's environmental documents and/or work products, an IC delay in producing them may impact SCE's ability to obtain required permits and/or license(s) in time to target the IC's requested ISD. Such delays would likely cause additional delays in the commencement of SCE's final design and engineering, procurement, and construction. These delays could increase any durations identified in this report and as stated above, could impact the ISD provided in Table H.1 ISD and COD Assessment.

3. Tap/Loop-in Distribution Substation Standard Durations

The standard duration identified for this type of facility is 46 – months. The 46-month duration is contingent upon the IC acquiring the appropriate land rights to construct the tap/loop-in substation required to interconnect the Generating Facility. Should the IC be un-successful with procuring the appropriate land for the tap/loop-in substation, the duration for this facility will increase to 60- months, since SCE will need to obtain the necessary land rights and perform the associated environmental and necessary licensing activities. If the IC does not accept the conditions associated with the 46 – month duration, SCE will update the duration for this type of facility in the Phase II study accordingly.

Conversely, SCE may reduce the duration to 39 – months for this type of facility on the condition that design, engineering, and procurement will be performed in parallel with licensing. If the IC accepts the 39 – month duration it is with the acknowledgment that the GIA payment schedule for the project will be front loaded and the 3rd Interconnection Financial Security posting will be required earlier than under the standard duration. If the IC does accept the conditions associated with the 39 – month duration, along with the commitment to procure the appropriate land for the tap/loop-in substation, SCE will tender an addendum to the report within the prescribed timelines in the GIP will update the duration for this type of facility in the Phase II study.

K. IN-SERVICE DATE AND COMMERCIAL OPERATION DATE ASSESSMENT

An ISD and COD assessment was performed for the Generating Facility to establish SCE's estimate of the earliest achievable ISD based on the cluster study process timelines and the time required for SCE to complete the facilities needed to enable physical interconnection as an Interim Deliverability Status or Energy-Only Deliverability Status interconnection (as applicable) for the Generating Facility. This date may be different from the IC's requested ISD and will be the basis for establishing the associated milestones in the draft GIA.

1. ISD Estimation Details

For the QC14 Phase I Interconnection Study, the estimated earliest achievable ISD is derived by the time requirements to complete the following:

1. QC14 Interconnection Study Cycle
2. Tender a draft GIA
3. Negotiate and execute the GIA
4. Longest duration associated with the facilities required to interconnect the Generating Facility (i.e., IF, RNU, and DU), per the durations specified in table G.1. above.

Table H.1 ISD and COD Assessment

Action or Assumption	Calendar Days or Months for Calculation	Item Description	Target Date
		Issuance of Phase I Interconnection Study Report	██████████
		Issuance of Phase II Interconnection Study Report	██████████
Add:	30 CD	Phase II Results Meetings	██████████
Starting Point:		For WDTs the assumption is that the TPD Results issued, and IC response provided before starting the draft GIA (the IC does have the option to start the GIA negotiation earlier)	██████████
Add:	30 CD	Earliest reasonable Tender draft GIA	██████████
Add:	90 CD	GIA negotiation time, execution, and related activities	██████████
Add: Construction Duration (Months)	46	Project execution duration outlined in the Study Report. Construction completion no earlier than date which reflects earliest ISD	██████████

The ISO will perform its Annual Reassessment (██████████) and Transmission Plan Deliverability (“TPD”) Allocation⁷ (██████████). Any changes in scope, cost, or schedule requirements that come out of ISO’s Annual Reassessment and (██████████) TPD Allocation will be reflected in a (██████████) Reassessment Report, which will be used to revise the draft GIA (if under negotiation) or amend the GIA (if already executed).

⁷ The TPD Allocation Process is estimated to be completed in April 2024. The actual date may vary.

Attachment 1:
Interconnection Facilities, Network Upgrades, and Distribution Upgrades
Please refer to separate document

Attachment 2:
Escalated Cost and Time to Construct for Interconnection Facilities, Reliability Network Upgrades,
Delivery Network Upgrades, and Distribution Upgrades
Please refer to separate document

**Attachment 3:
Allocation of Network Upgrades for Cost Estimates and Maximum Network
Upgrade Cost Responsibility**

Please refer to separate document

Attachment 4:

SCE's Interconnection Handbook

Preliminary Protection Requirements for Interconnection Facilities are outlined in SCE's Interconnection Handbook at the following link:

<https://on.sce.com/InterconnectionHandbook>.

Attachment 5:
Short-Circuit Duty Calculation Study Results
Please refer to the Appendix H of the Area Report

Attachment 6:

[Redacted]

[Redacted]

[Redacted]

[Redacted]

[Redacted]

[Redacted]

[Redacted]

[Redacted]

Attachment 7:
Subtransmission Assessment Report
Please refer to separate document